

# ac Susceptibility Measurements in High- $T_c$ Superconductors

## Experiment ACS

University of Florida — Department of Physics  
PHY4803L — Advanced Physics Laboratory

### Objective

You will learn how to use an alternating current susceptometer to study the magnetization induced in various magnetic materials in response to the alternating magnetic field inside a driven solenoid. In particular, a high- $T_c$  superconductor is studied as a function of temperature near the superconducting transition. A two-phase lock-in amplifier is used to measure the amplitude of the sample magnetization and its phase relative to that of the driving magnetic field.

### References

- M. Nikolo, "Superconductivity: A guide to alternating current susceptibility measurements and alternating current susceptometer design," *Am. J. Phys.* **63**, 65 (1995).
- W. Lin, L.E. Wenger, J.T. Chen, E.M. Logothetis, and R.E. Soltice, "Nonlinear magnetic response of the complex AC susceptibility in the  $\text{YBa}_2\text{Cu}_3\text{O}_7$  superconductors," *Physica C* **172**, 233-241 (1990).
- C. Kittel, *Introduction to Solid State Physics*, 6th ed. (Wiley, 1986). See Chapter 12 and Appendix K.

N. W. Ashcroft and N. D. Mermin, *Solid State Physics*, (Holt, Rinehart and Winston, 1976). Chapter 34 gives introductory descriptions of superconductivity and lists references for more advanced reading.

W. E. Pickett et al., "Fermi Surfaces, Fermi Liquids, and High-Temperature Superconductors," *Science* **255**, 46 (1992).

M. Tinkham, *Introduction to Superconductivity* (McGraw-Hill, 1996).

### Introduction

The equipment list for this experiment includes a vacuum pump, liquid nitrogen ( $\text{LN}_2$ ) cryostat, ac susceptometer, function generator, two-phase lock-in amplifier, thermocouple temperature sensor and 5 1/2 digit multimeter, computer data acquisition system, and  $\text{YBa}_2\text{Cu}_3\text{O}_7$  (YBCO) superconductor. Theoretical considerations include superconductivity, magnetization, susceptibility, Faraday's law of induction and ac circuit analysis. Many experimental and theoretical aspects will only be treated at a level necessary to understand their application to this experiment. The interested student is encouraged to explore the

references, textbooks, and other material to fill in the gaps.

## High- $T_c$ superconductor

Superconductivity was discovered in 1911 by H. Kammerlingh Onnes in Leiden. After decades of detailed experiments, a thorough understanding of “conventional” superconductors became available in 1956 with the advent of the Bardeen-Cooper-Schrieffer (BCS) theory. There are now hundreds of known compounds which exhibit this remarkable phenomenon. The field had a major upheaval in 1986, when Bednorz and Müller at the IBM Research Laboratory in Zurich discovered superconductivity in  $\text{La}_{2-x}\text{Sr}_x\text{CuO}_4$ . The discovery has led to a new class of oxide superconductors with significantly higher transition temperatures  $T_c$ . These “high- $T_c$  oxide superconductors” are now a subject of intense experimental and theoretical study, as there are experimental indications that they differ from conventional superconductors. They also provide a convenient demonstration of superconductivity in the laboratory, requiring only  $\text{LN}_2$  as the cryogen.

Superconductors possess a unique collection of physical behaviors: zero electrical resistance, the Meissner effect (perfect dc diamagnetism), an energy gap  $\Delta$  in their electronic excitation spectrum, the quantization of magnetic flux, and the Josephson effect. This experiment studies their magnetic response, in particular their ac diamagnetism at low frequency ( $\hbar\omega \ll \Delta$ ).

Any conductor will partially shield its interior from changing magnetic fields through the generation of eddy currents. Because of resistive losses, the shielding is incomplete. In a perfect conductor (zero resistance material) the shielding becomes perfect; the magnetic field cannot change in a perfect conductor.

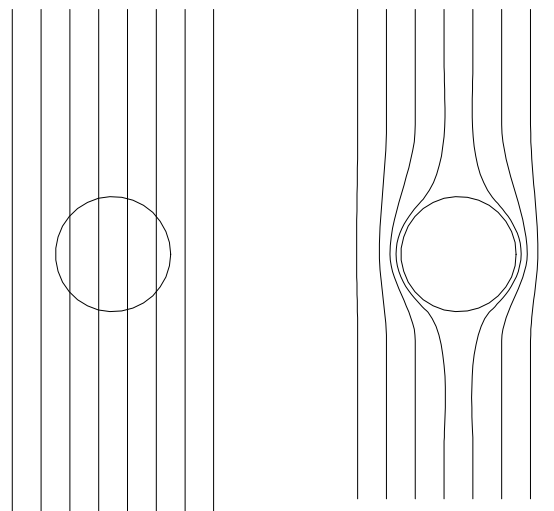

Figure 1: The Meissner effect in a superconducting sphere cooled in a dc magnetic field. Upon passing below the transition temperature, the field is expelled from the material (right).

Superconductors are perfect conductors, but they shield their interiors from dc magnetic fields as well. Not only  $dB/dt$  but also  $B$  is zero inside a superconductor. The expulsion of static magnetic fields from the interior of superconductors is called the Meissner effect and will not be considered in this experiment. However, it should be pointed out that the Meissner effect is not a consequence of zero resistance. Figure 1 (left) shows a superconducting sphere in a dc magnetic field above the transition temperature. The material is in the normal state and the field completely penetrates it. The sample is then cooled into the superconducting state and spontaneously generates eddy currents completely expelling the magnetic field. If the superconducting transition is simply a transition to a perfectly conducting state (where  $dB/dt = 0$ ), the magnetic field could not change on cooling through the transition, and would be trapped in the material. Superconductors are more than perfect conductors!

## Susceptibility

A magnetic material is described by its magnetization  $\mathbf{M}(\mathbf{r})$ , or magnetic dipole moment per unit volume at points  $\mathbf{r}$  throughout its volume. Recall that the SI unit of magnetic dipole moment is  $\text{A}\cdot\text{m}^2$  and thus the SI unit of magnetization is  $\text{A}/\text{m}$ .

Determining the magnetic field associated with an arbitrary magnetization distribution,  $\mathbf{M}(\mathbf{r})$ , can be difficult. However, if the material is in the shape of a long cylinder (solenoidal) and the magnetization is constant and points along the cylinder axis, the situation simplifies.

Before considering this special case, recall that for a long solenoid carrying a current  $I$ , the magnetic field outside the solenoid is zero and inside  $B = \mu_0 nI$  where  $n$  is the solenoid's number of turns per unit length. The field depends only on the product  $nI$  which can be called the current density and has SI units of  $\text{A}/\text{m}$ , the same as  $\mathbf{M}$ .

The microscopic model for bulk magnetization is that it arises from the contributions of a great many atomic or molecular current loops. In the interior of the material, the current from adjacent loops are in opposite directions and these currents produce no magnetic field. (The cancelation is strictly correct only if the magnetization is constant.) On the material's boundary, however, the loop currents are unopposed, and lead to a surface current density (current per unit length)  $\mathbf{M} \times \mathbf{n}$ , where  $\mathbf{n}$  is the surface normal.

For a constant axial magnetization  $M$  throughout a long, cylindrically-shaped sample, the surface current density is constant and equal to  $M$ . This current circulates around the cylinder like the current in a solenoid, and the magnetic field is the same as that of a solenoid with  $nI = M$ , i.e., inside the material  $B_{\text{in}} = \mu_0 M$  (a constant), and outside

$B_{\text{out}} = 0$ .

If such a sample is placed in a uniform magnetic field  $B_a$  oriented parallel to the sample axis, the net magnetic field is the superposition of the applied field and the field due to the magnetization. If the external field is written  $B_a = \mu_0 H_a$ , (which defines the magnetic intensity  $H_a$ ) the magnetic field outside is just  $B_{\text{out}} = \mu_0 H_a$  and the field inside becomes

$$B = \mu_0(H_a + M) \quad (1)$$

For some materials the magnetization is zero in the absence of an applied field and only becomes non-zero as a response to the applied field. For linear response materials, the magnetization will be aligned with (or against) the field and proportional to it. That is, we can write

$$M = \chi H_a \quad (2)$$

which defines the material's susceptibility  $\chi$ . Equation 1 can then be expressed

$$B = \mu_0(1 + \chi)H_a \quad (3)$$

For paramagnetic materials,  $\chi > 0$  and the magnetic field is enhanced in the presence of the material. For diamagnetic materials,  $\chi < 0$  and the field inside the material is reduced.

Non-linear materials in dc magnetic fields can show saturation effects, hysteresis, and magnetization containing terms proportional to higher (odd) powers in the applied field.  $M = \chi_1 H_a + \chi_3 H_a^3 + \dots$

**Exercise 1** *Why can the dc magnetization only include terms proportional to odd powers of the applied field? Hint: What must happen to  $M$  if the direction of  $H_a$  reverses?*

If the applied magnetic field is not constant but is instead oscillating sinusoidally along the sample axis at a frequency  $\omega$ , i.e.,

$$B_a = \mu_0 H_0 \cos \omega t \quad (4)$$

the situation (for a linear magnetic material) is only slightly more complicated than that for a dc field. The general form for a material's magnetization in an ac magnetic field is also sinusoidal at the frequency of the applied field, but it can be shifted in phase relative to the applied field. Relative to the applied field as given by Eq. 4, the general form for the magnetization can be expressed

$$M = H_0(\chi' \cos \omega t + \chi'' \sin \omega t) \quad (5)$$

Phasor representations are very useful for working with ac quantities. Recall phasors as rotating vectors in the complex plane. Euler's identity in the form

$$e^{i\omega t} = \cos \omega t + i \sin \omega t \quad (6)$$

illustrates the rotational behavior of a phasor of unit length with oscillating real ( $\cos \omega t$ ) and imaginary ( $\sin \omega t$ ) components. Also recall that the real physical quantity associated with a phasor is the projection of the phasor on the real axis and is obtained by taking the real part (abbreviated  $\Re$ ) of the phasor quantity.

The phasor representation for an applied ac field of the form of Eq. 4 would be expressed

$$H_a = H_0 e^{i\omega t} \quad (7)$$

(with  $B_a = \mu_0 H_a$ ). A (linear) material's susceptibility can then be specified as a complex constant

$$\chi = \chi' - i\chi'' \quad (8)$$

and the magnetization phasor can then be expressed

$$M = \chi H_a \quad (9)$$

which is the ac equivalent of Eq. 2 for dc fields.

**Exercise 2** Show how Eq. 7 is consistent with Eq. 4. Show how Eq. 9 with Eqs. 8 and 7 is consistent with Eq. 5.

For some materials,  $\chi''$  is nearly zero. If  $\chi'' = 0$ , the magnetization will be perfectly in phase with  $H_a$  for a paramagnetic material ( $\chi' > 0$ ) and will be 180° out of phase for a diamagnetic material ( $\chi' < 0$ ). With non-zero values of  $\chi''$ , the magnetization given by Eq. 5 will be neither perfectly in phase or out of phase with the applied field.

It turns out that only positive values of  $\chi''$  are physically possible (and thus that the magnetization can only lag the applied field). That only  $\chi'' > 0$  is physically possible can be seen from the relationship between the sign of  $\chi''$  and the direction of energy flow between the sample and the applied field. The power density  $p$  (power per unit volume) absorbed in the sample is given by

$$p = -M \frac{dB_a}{dt} \quad (10)$$

**Exercise 3** Show that averaged over a complete cycle,

$$p_{\text{av}} = \frac{1}{2} \mu_0 \omega H_0^2 \chi'' \quad (11)$$

*Hint: With phasors the formula becomes  $p_{\text{av}} = \frac{1}{2} \Re\{-M dB_a^*/dt\}$  where  $B_a^*$  is the complex conjugate of  $B_a$ .*

Only  $p_{\text{av}} > 0$  ( $\chi'' > 0$ ) is energetically possible. In this case, the sample absorbs energy from the applied field which goes into heating the sample. Were  $p_{\text{av}} < 0$  ( $\chi'' < 0$ ), rather than absorbing energy, the sample would be continually radiating energy — a violation of the second law of thermodynamics.

Non-linear magnetic materials in ac fields develop magnetization with higher harmonic components in addition to the fundamental expressed by Eq. 5. Thus, non-linear materials produce non-sinusoidal magnetization. We will emphasize the linear behavior, but keep your eye out for evidence of non-linear behavior.

## Solenoid in an ac field

Since the surface current of a uniformly magnetized cylindrical sample is equivalent to a solenoidal current density  $nI = M$ , it will be insightful to investigate the behavior of a solenoid in applied ac field. We start however with the dc behavior.

**Exercise 4** (a) For a solenoid of radius  $R$  and length  $D \gg R$  carrying a current  $I_s$ , the self-induced flux through the solenoid is defined by  $\Phi_s = NB_sA$ , where  $N = nD$  is the total number of turns and  $A = \pi R^2$  is the cross-sectional area. Show that  $\Phi_s$  can be expressed

$$\Phi_s = LI_s \quad (12)$$

where  $L = \mu_0 n^2 V$ , and  $V$  is the solenoid volume.

$L$  is called the self inductance.

The solenoid is placed with its axis along an applied field  $B_a$ .

**Exercise 5** Show that the flux through the solenoid due to the applied field  $\Phi = NB_aA$  can be written

$$\Phi_a = LI_a \quad (13)$$

where the pseudo-current  $I_a$  is defined by  $I_a = B_a/\mu_0 n$ .

Thus, if the solenoid carries a current  $I_s$ , the net flux through the solenoid can be expressed

$$\Phi = L(I_s + I_a) \quad (14)$$

If the applied field  $B_a$  oscillates at a frequency  $\omega$ ,  $\Phi_a$  will oscillate, and from Faraday's law of induction, an ac voltage

$$V = -d\Phi/dt \quad (15)$$

will develop across the open solenoid ends. If a resistive load  $R$  is placed in series with the solenoid, an oscillating solenoid current  $I_s = V/R$  will develop, which then must be taken into account.

**Exercise 6** Show that if  $B_a$  is given by Eq. 4 (i.e.,  $I_a = I_{a0} \cos \omega t$  with  $I_{a0} = H_0/n$ ), then the current  $I_s$  in the solenoid will be

$$I_s = I_{a0}(\chi' \cos \omega t + \chi'' \sin \omega t) \quad (16)$$

where

$$\chi' = -\frac{\omega^2 L^2}{R^2 + \omega^2 L^2} \quad (17)$$

$$\chi'' = \frac{R\omega L}{R^2 + \omega^2 L^2} \quad (18)$$

*Hint: This problem is easy if you represent  $I_s$ ,  $I_a$ ,  $\Phi$ ,  $V$  as phasors. Alternatively, you can assume the solution as given by Eq. 16 and solve for  $\chi'$  and  $\chi''$ . Either way you will need the fact that the solenoid current obeys  $V = I_s R$ , with  $V$  given by Eq. 15 and  $\Phi$  given by Eq. 14.*

We can now compare the solenoid behavior with that for a linear induced magnetization in a solenoid-shaped sample. The magnetization that would produce the same field as the solenoid is given by  $M = nI_s$ . With  $I_s$  as given by Eq. 16, this produces a magnetization  $M$  as given by Eq. 5.

**Exercise 7** The instantaneous electrical power delivered to the solenoid by the oscillating magnetic field is given by  $P = VI_s$  and is oscillatory with a DC offset. (a) Show that the DC component (average value over a complete cycle) is given by

$$P_{av} = \frac{1}{2} \omega L I_{a0}^2 \chi'' \quad (19)$$

(b) Show that this is consistent with

$$P_{av} = \frac{1}{2} |I_s|^2 R \quad (20)$$

demonstrating that the energy is going into joule heating of resistive component of the solenoid. (c) Show that this calculation agrees

with Eq. 11. Hints: Keep in mind that Eq. 11 is for a power density not a power. Using phasors the formula for the average power is  $P_{\text{av}} = \frac{1}{2} \Re[VI_s^*]$ , where  $I_s^*$  is the complex conjugate of  $I_s$ .

**Exercise 8** For a given frequency, as the temperature  $T$  decreases, the resistance decreases from a high value ( $R \gg \omega L$ ) to a low value ( $R \ll \omega L$ ). Assume that most of this change occurs within a region  $\Delta T$  around  $T_c$ , where  $T_c$  is the transition temperature of the superconductor. Sketch the temperature dependencies of  $\chi'(T)$  and  $\chi''(T)$ . You should expect to see these dependencies in the experiment that follows.

In a superconductor,  $B$  must be zero and the effective magnetization must obey  $M = -H_a$ . Thus  $\chi' = -1$  and  $\chi'' = 0$  (and there can be no non-linear magnetization in a superconductor). However, during the transition to the superconducting state the study of the magnetization expressed by Eq. 5 (and higher harmonics) can lead to insights into the mechanisms responsible for the creation and destruction of superconductivity.

**Exercise 9** (a) Equation 17 indicates  $\chi' < 0$  and thus that a solenoid acts as a diamagnetic material. Why is this expected? (b) Use Eqs. 17 and 18 to obtain the effective susceptibility of a solenoid with a zero resistance. Is the result reasonable?

## Susceptometer

The sample magnetization is studied using a conventional ac magnetic susceptometer. The susceptometer probe illustrated in Fig. 2 includes a primary (excitation) solenoid coil which produces a near-uniform ac magnetic field when driven by an ac source. Inside the primary coil is the secondary coil consisting of

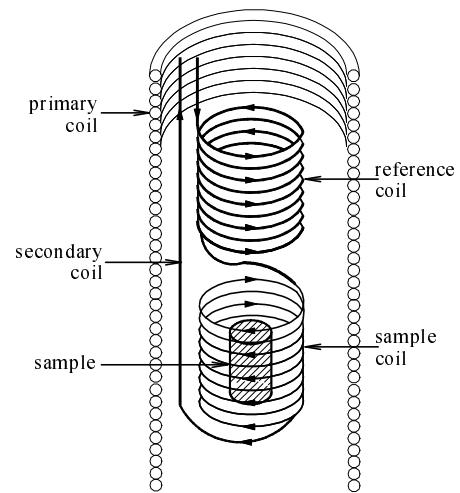

Figure 2: Arrangement of the primary coil (cut-away), the secondary coil, and the sample in the susceptometer. Note the secondary coil consists of the sample coil (bottom) and the counter-wound reference coil (top).

two pickup coils which are wound in opposite directions and electrically connected in series. The pickup coils occupy opposite halves of the primary coil volume. The sample is placed in one of the pickup coils (the sample coil) while the other pickup coil (the reference coil) is left empty.

The ac voltage  $V$  across the secondary coil is due to Faraday induction.

$$V = -\frac{d\Phi}{dt} \quad (21)$$

where  $\Phi$  is the net flux through the entire secondary (both the sample and reference coil) and includes contributions from both the applied field and the field due to the sample magnetization. The self-induced flux from the secondary can be neglected because the secondary is connected only to high impedance (10 M $\Omega$ ) voltage metering equipment (oscilloscope, lock-in) and thus carries negligible current.

Because the two pickup coils are wound in opposite directions and connected in series, the net secondary flux due to the applied field will be small. It is not exactly zero because of imperfections in probe construction, and thus there is some small mismatch in the flux for the sample and reference coils. Of course, the net secondary flux due to the mismatch,  $\Phi_{mm}$ , will be proportional to the primary field

$$\Phi_{mm} = \alpha_{mm} B_a \quad (22)$$

where  $\alpha_{mm}$  is an effective mismatch area which may be positive or negative depending on winding directions, and whether the sample or reference coil has the larger flux. Consequently, there will be some secondary signal  $V = -d\Phi_{mm}/dt$  (called the mismatch signal) even with no sample present. If the primary field is given by Eq. 4, then the mismatch signal will be

$$V = V_{mm} \sin \omega t \quad (23)$$

where  $V_{mm} = \alpha_{mm} \mu_0 \omega H_0$  gives the amplitude of the voltage due to mismatch.

If a sample is present (in the sample coil), the magnetic field  $\mu_0 M$  associated with the induced magnetization will unbalance the fluxes in the sample and reference coils and there will be a large net flux  $\Phi_m$  in the secondary. We could write

$$\Phi_m = \alpha_m \mu_0 M \quad (24)$$

with the effective area  $\alpha_m$  expected to be much larger than  $\alpha_{mm}$ . Again, the sign of  $\alpha_m$  depends on the winding directions. If  $M$  is given by Eq. 5, there will be an induced secondary voltage  $V = -d\Phi_m/dt$  given by

$$V = V_m (\chi' \sin \omega t - \chi'' \cos \omega t) \quad (25)$$

where  $V_m = \alpha_m \mu_0 \omega H_0$  sets the scale for the secondary voltage due to the sample.

The net secondary voltage will include both sources, Eqs. 23 and 25.

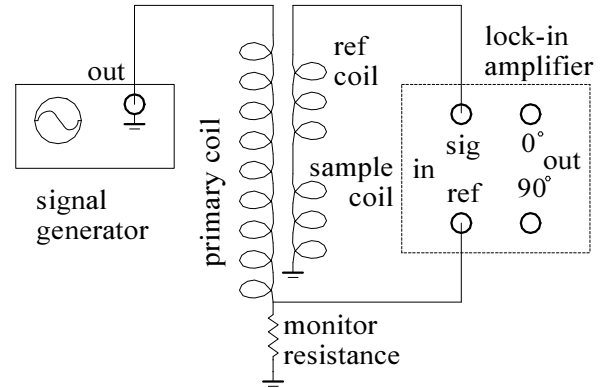

Figure 3: Equivalent circuit for the function generator, susceptometer and lock-in.

## Primary field, current

The primary field is, of course, directly proportional to the current  $I_p$  in the primary coil.

$$B_a = \kappa I_p \quad (26)$$

**Exercise 10** *The proportionality constant  $\kappa$  can be estimated from the primary coil geometry. Estimate  $\kappa$  (in Gauss/Amp) based on the infinite solenoid formula ( $B = \mu_0 n I$ ) and the (approximate) primary coil geometry of 5 cm long, 350 turns, i.e.,  $n = 70/\text{cm}$ . The field has been measured with an axial Hall probe and agrees well (within a few percent) with this approximation. The average diameter of the primary coil is about 1.7 cm.*

A small junction box allows a variable resistor to be inserted in the return path for the primary. The voltage across the resistor appears at the BNC terminal labeled **Monitor** when an external resistor is placed across the banana jacks. This voltage should be very nearly in phase with the current in the primary and is used for the lock-in reference. The amplitude of the voltage, together with the value of the monitor resistance is used to calculate the amplitude of the primary current.

## Lock-in detection

In our application, the two-phase lock-in amplifier is used to measure both the amplitude of the secondary voltage and its phase (how much it lags or leads) relative to the monitor voltage. The lock-in takes the monitor voltage as the *reference* input and it takes the secondary voltage as the *signal* input. Although the amplitude of the reference voltage is relatively unimportant, the manufacturer recommends its value be near  $1 V_{\text{rms}}$  for optimum sensitivity.

The origin of time is arbitrary, so the reference voltage can be expressed

$$V_r = V_{r0} \cos \omega t \quad (27)$$

Relative to this reference, an arbitrary signal voltage (at the same frequency) can be expressed

$$V_s = V_{s0} \cos(\omega t - \delta) \quad (28)$$

where  $\delta$  is the phase angle by which the signal lags the reference. Equation 28 can also be expressed

$$V_s = V_x \cos \omega t + V_y \sin \omega t \quad (29)$$

where

$$V_x = V_{s0} \cos \delta \quad (30)$$

$$V_y = V_{s0} \sin \delta \quad (31)$$

The lock-in provides direct measures of  $V_x$  and  $V_y$ . (The lock-in outputs are actually rms values with signs, i.e.,  $V_x/\sqrt{2}$  and  $V_y/\sqrt{2}$ . With a change of mode, the lock-in can also be made to provide  $V_{s0}/\sqrt{2}$  and  $\delta$ .)

Assuming that the monitor voltage (lock-in reference) is perfectly in-phase with the primary field and that the secondary voltage (signal) is given by the sum of Eqs. 23 and 25, the lock-in outputs are expected to be

$$V_x = -V_m \chi'' \quad (32)$$

$$V_y = V_{mm} + V_m \chi' \quad (33)$$

Note, however, that the lock-in has a reference phase offset adjustment which allows one to introduce an arbitrary, constant phase shift between the reference and signal voltages. The phase offset is often adjusted when there may be an apparatus-dependent phase shift in the reference and/or the signal, say due to cable lengths or stray impedances. To correct for the unknown phase shift, one needs some condition that can be realized experimentally where the relative phase between the reference and signal is known. If such a condition can be achieved, the lock-in phase adjustment can be set to produce the known phase difference, and as the experimental conditions change to those where the phase relationship is unknown, the results can be interpreted based on this setting.

For example, it is quite reasonable to expect small phase shifts in either or both our signal and reference voltages. Furthermore, as they may be affected by circuit impedance, such apparatus-dependent phase shifts may change with temperature. In this experiment, if the reference and signal voltage have no apparatus-dependent phase shifts (or if both have the same shift), there should be no (in-phase)  $x$ -signal when the sample is perfectly superconducting or when the sample is non-magnetic since in both cases  $\chi'' = 0$ . This condition can be used to calibrate the phase at room temperature, just above, and just below the superconducting transition. Simply adjust and record the phase setting needed to produce no  $x$ -output.

## Thermocouple Measurements

A detailed discussion of the issues associated with using thermocouples to measure temperature can be found in the auxiliary material for this experiment. A basic thermocouple is depicted in Fig. 4. The figure shows that there



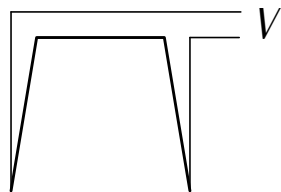

Figure 4: Model for a thermocouple. The thick wire is made of one metal and the two thin wires are made of another. A voltage  $V$  develops when the two junctions between the dissimilar metals are at different temperatures.

are two junctions between the two wires of dissimilar materials (where the thick and thin wires meet in the figure). With one of these junctions, called the reference junction, in an ice bath (i.e., at  $0^\circ\text{C}$ ) and the other, called the sample junction, at some temperature  $T$ , the voltage  $V$  will be given to within some error limits by  $V = V_{\text{tab}}(T)$  which can be looked up in the reference table supplied in the auxiliary material. The thermocouple can also be used with the reference at any known temperature  $T_{\text{ref}}$ , in which case the voltage  $V$  will be the difference in the tabulated reference voltages for each temperature:  $V = V_{\text{tab}}(T) - V_{\text{tab}}(T_{\text{ref}})$

An E-type thermocouple is used to measure the sample temperature. The thermocouple voltages will be in the few millivolt range and will be measured using the Keithley 199 (a 5 1/2 digit multimeter).

Connect the thermocouple to the Keithley 199 voltmeter, set it for the most sensitive DC volts scale. Remove the junction from the sample holder (it slides out) and record the measured voltages while immersing the thermocouple junctions (reference and sample) in the four possible combinations with one in  $\text{LN}_2$  (77.35 K or  $-195.8^\circ\text{C}$ ) and the other in an ice bath (273.15 K or  $0^\circ\text{C}$ ).

Small thermally induced voltages can be produced where the thermocouple leads attach

to the voltmeter. Check how much the voltage changes as you heat up (using your fingers) one or the other of the connections at the voltmeter.

You may obtain non-zero voltages when both junctions are in  $\text{LN}_2$  or both are in the ice bath. According to the simplified theory, these conditions should both produce 0 V. Furthermore, your two measured voltages for the conditions with one junction in an ice bath and the other in  $\text{LN}_2$  may not be negatives of one another as predicted. As you will see, these four observations are largely explained by a constant offset error in the measured voltages, and it is reasonable to subtract an offset voltage from all readings as a correction. Choose a single offset voltage that gives corrected voltages closest to 0 V when the reference and sample junctions are in the same bath, and opposite voltages for the two  $\text{LN}_2$ /ice bath conditions. There may still be a significant difference in the magnitude of the corrected voltages for the  $\text{LN}_2$ /ice bath conditions and the value predicted by the reference table, but some difference (roughly  $50\text{-}100\ \mu\text{V}$ ) is reasonable based on manufacturing tolerances in the wire composition. When both junctions are in the ice bath or both are in the  $\text{LN}_2$ , the correction should make them both closer to zero, but it may still leave them unequal and nonzero. It should be apparent from your measurements that no single offset correction will make these two readings zero. Some additional studies will be needed to fully understand this effect. However, even with this incomplete understanding, reasonable error limits on the random and systematic errors in the temperature measurements can be inferred.

When used in the experiment, the sample temperature is most readily obtained by correcting the raw thermocouple voltage with the offset as determined above and then using a polynomial interpolation. The polyno-

$n$	$C_n$
0	273.14
1	17.073
2	-0.2186
3	0.02070
4	-0.01966
5	$-0.9953 \times 10^{-2}$
6	$-2.1504 \times 10^{-3}$
7	$-2.1280 \times 10^{-4}$
8	$-0.8234 \times 10^{-5}$

Table 1: Eighth order polynomial coefficients for an E-Type thermocouple over the range from room temperature to LN<sub>2</sub> temperature.

mial to use is based on reference table values. Table 1 gives coefficients for an eighth order polynomial that will give the NIST table temperature  $T$  (in Kelvin) to better than 0.1 K over the range from 75 K to 295 K for a given (corrected) thermocouple voltage  $V$  (where  $V$  is in mV and negative below the ice point). The thermocouple wire manufacturer indicates possible errors to be on the order of 2 K.

To perform the calculation, a nested formula is more efficient, e.g.,  $T = C_0 + V * (C_1 + V * (C_2 + V * C_3))$  for a third order polynomial. All eight orders must be used with the data of Table 1.

## Safety Considerations

Handling of cryogenic fluids requires caution since serious frost bite may result from mishandling. In particular, never get cryogenic fluids in eyes or allow the fluid to remain in contact with your skin. **DO NOT PLAY AROUND WITH CRYOGENIC FLUIDS.** Operating valves and other metal parts that are or have been in contact with cryogenic fluids requires wearing special protective

gloves. Otherwise, it is best to handle cryogen containers and valves with bare hands. The reason is that most gloves absorb cryogenic fluids which would then remain in contact with the skin too long, possibly causing frost bite. On the other hand, fluids spilled over bare skins will rapidly escape and/or evaporate, reducing the risk of frostbite. If you spill the liquid on your feet, quickly remove both shoes and socks to avoid freezing your toes. The leather and the fabric of your footwear have most likely soaked up the cold liquid, although they appear dry. The consequence of not following this advice can be serious and extremely painful.

The vacuum chamber for the apparatus will be cooled to LN<sub>2</sub> temperatures in a glass dewar. Read and observe the procedures for evacuating, cooling, and warming the chamber. Failure to follow proper precautions can lead to explosions and flying shards of metal and dewar glass.

The health effects of the superconducting compound YBCO used in this lab have not been studied in detail. Therefore, you are advised to wash your hands after handling the sample. As was discussed in the lecture, **NEVER** eat in the lab and always wash your hands after handling any samples.

## General Procedures

Do not perform any of the procedures in this section until instructed to do so in the main *Procedure* section. At that time please reread and follow the instructions given here.

The susceptometer is mounted inside a vacuum chamber to decrease heat transfer rates. The superconducting sample is thermally connected to the vacuum chamber by a small copper braid and will cool down reasonably slowly when the chamber is evacuated and cooled to LN<sub>2</sub> temperatures.

The outer can of the vacuum chamber easily rolls off a lab table. If it falls on the floor or otherwise becomes dented, the vacuum seal will be ruined. **When not in use store the can (seal-side in) in the wooden block provided for this purpose.** Furthermore, keep the block away from table edges.

### Probe Evacuation

1. Close the purge and pump valve and turn on the vacuum pump.
2. Wipe the brass contacting surfaces with a clean soft towel and coat both surfaces with a **thin** layer of silicon grease.
3. Open the pump valve to the vacuum chamber, gently rotating the can with a slight pushing against the sealing surfaces. As a vacuum is achieved, the rotation will become difficult and can be stopped. Continue pumping while you make measurements.

### Probe Cooling

1. Fill the dewar about 3/4 full with LN<sub>2</sub>. (LN<sub>2</sub> can be obtained from the cryogenics shop on the basement floor.)
2. Lower the can — slowly enough to avoid rapid boiling of the LN<sub>2</sub> — until it is completely submerged.
3. The pressure should fall as the chamber cools. If it rises, LN<sub>2</sub> may be seeping into the chamber — proceed to the probe warming and check with the instructor.

### Probe Warming

1. Raise the chamber completely out of the dewar. Continue pumping.

2. The chamber can be warmed by lowering it completely into the popcorn popper and running the popper on a Variac (adjustable ac voltage supply). While pumping, warm the chamber with the Variac at a fairly low setting. When the thermocouple temperature gets slightly above room temperature turn off the heating. Lower the ac voltage as necessary to make sure that the chamber never gets so hot that you can not hold your finger on it. **Never walk away from the chamber with the heating on.** You could overheat and destroy the susceptometer. Do not open a cold chamber to air; water will condense on the susceptometer making it difficult to evacuate later. As a precaution always arrange things so that if, during the warming cycle, the vacuum can should slide off the chamber, it will not fall to the floor and possibly become dented. If you use the popcorn popper and position it and the probe properly, the can would safely fall into the popper.
3. Again, make certain that the vacuum can will not fall on the floor as you next let air into the chamber. Either lower the can so it is within a centimeter of the table or place a block under the can leaving no more than a centimeter of space between them.
4. While holding the can in your hand, close the pump valve and open the vent valve. You should hear the air rushing into the probe which should then be at atmospheric pressure. So be careful. The can could easily fall off on its own at this point. If the can does not fall off, hold the top brass sealing surface **not the support tubing** and gently twist and pull the can straight off. If the can does not come off easily, it may still be under vac-

uum. Check that the pump valve is closed and the vent valve is open. **Place the can in its holder.**

5. Turn off the pump and open the pump valve.

## Procedure

1. Keep the susceptometer at room temperature and open to the air for now. Slide the superconducting sample out of the susceptometer (it is held by a single teflon screw). You will first test the operation of the susceptometer with no sample (signal from coil mismatch only).
2. Using an ohmmeter, measure the resistances of the primary (approximately  $3\ \Omega$ ) and the secondary coil (approximately  $60\ \Omega$ ). Check the electrical isolation of the two coils from each other and from the coil supports. Report problems to the instructor.
3. Disconnect the function generator from the primary coil and measure its output directly on an oscilloscope. Set the amplitude to  $10\ V_{pp}$  and observe that it is independent of frequency. (Make sure that load-impedance selection has been set to HIGH-Z instead of  $50\ \Omega$  and leave it at this setting throughout the experiment.)
4. Reconnect the function generator to the primary circuit and monitor the primary current (monitor voltage) and secondary voltage with the oscilloscope. Trigger on the primary current. **Don't try to monitor the primary coil voltage since neither end of the coil is grounded.** Keep the generator amplitude (at the  $10\ V_{pp}$  setting) and monitor resistance (about  $10\ \Omega$  will work well) fixed during the measurements in the next step.

5. Draw and analyze a circuit model including: the function generator (ideal source in series with a  $50\ \Omega$  resistance), primary coil (ideal inductor in series with a resistor as measured previously), and the monitor resistance. Measure the primary current and secondary voltage as a function of frequency from 100 Hz to 200 kHz in a 1, 2, 5 sequence. Above 100 or 200 kHz stray circuit capacitances not included in the model can lead to unpredicted resonances in the primary current.

**C.Q. 1** *Plot primary current vs. frequency and use this data with the model to determine the primary's inductance. Compare with a calculated inductance based on the geometry given previously. Plot the ratio of the secondary's voltage to the primary current as a function of frequency and explain its behavior.*

Hopefully, you have verified in the previous step that the amplitude of the secondary voltage for a given primary current is proportional to the frequency. Thus, higher frequencies will give larger signals. However, the impedance of the primary also increases with frequency and therefore the maximum attainable primary current and primary field decrease. For a frequency around 1 kHz, the secondary signals are generally large enough to be easily measured and the maximum primary field can be made large enough to observe the effects of large amplitude applied fields on the superconducting transition.

6. Set the function generator frequency to 1 kHz.
7. Maintaining the oscilloscope connections, connect the lock-in — monitor voltage to the reference input, secondary to the signal input. Turn off all lock-in input filtering and output offsets. Set the output time constant to 1 sec. When making

measurements make sure the lock-in sensitivity is set to a reasonable value; too low and the readings will lose accuracy, too high and the input amplifiers will saturate.

8. The monitor resistance and function generator amplitude should be simultaneously adjusted to produce the desired current amplitude in the primary while also producing about a  $1 V_{\text{rms}}$  monitor voltage. Adjust the function generator amplitude and/or monitor resistance to get an ac magnetic field amplitude of a few Gauss. Do not trust the nominal resistance values of the Ohm-ranger, particularly for small values. If the directly measured resistance value is unstable or much larger than the nominal one, flip up and down *all* the switches several times until the problem disappears.
9. Adjust the reference phase setting of the lock-in to zero. With just the mismatch signal, the primary current and secondary voltage should be  $90^\circ$  out of phase. Thus, there should be nearly no signal on the  $x$ - or in-phase output and a maximum signal (plus or minus) on the  $y$ - or quadrature signal. Record how the  $x$ - and  $y$ -outputs change as you vary the lock-in's reference phase control and explain your results. Determine and record the reference phase setting which zeros the  $x$ -output. How well can this be done? Does it depend on the primary field amplitude?

A ferrite core inductor is used for this part of the experiment. The core is cylindrically shaped and made from ferrite—a ceramic material having a large  $\chi'$  and a small  $\chi''$ . The inductor is made by winding a solenoid around the core. The leads of the solenoid can be left open so there is no inductor current or they

can be shorted to see the effects of non-zero inductor current when it is placed in an ac magnetic field.

10. Keep the inductor open-circuit. Watch the secondary voltage on the oscilloscope and on the lock-in outputs as the core is just barely inserted into the sample coil. Record whether the extra flux from the ferrite core creates a signal which adds to or subtracts from the mismatch signal. What does this behavior imply about the mismatch (no sample) signal? With no sample, does the sample coil (lower) or the reference coil (upper) have larger flux? What does this behavior imply about the sign of  $V_m$  in Eqs. 32 and 33? Gradually insert it farther into the susceptometer watching as the amplitude of the secondary voltage goes through several extrema. Describe how the oscilloscope trace (amplitude and phase) and lock-in outputs change during this step, and explain the observations in terms of the flux changes going on in the sample and reference coils.
11. Since the inductor was open circuit in the last step, there was no current in it. Consequently, there is only very low resistive energy losses due to the small  $\chi''$  of the core. Watch how things change when the leads are shorted. Starting with the inductor open circuit and inserted to the first maximum, describe how the secondary signal changes. Relative to the primary current (monitor voltage), does it advance (lag) or retreat (lead)? Does the amplitude increase or decrease? Also, describe the changes in the lock-in outputs. Explain how these observations are consistent with the expected changes in  $\chi'$  and  $\chi''$  when the inductor windings begin conducting.

12. Is there any position of the inductor where the secondary amplitude goes to zero? Explain why your answer depends on whether the inductor is open circuit or shorted.
13. Remove the inductor and gradually insert the iron nail into the sample coil. Describe how the lock-in signals change. Explain and compare with the prior observations when inserting the inductor (both open circuited and shorted). How do your observations show that for the nail material both  $\chi'$  and  $\chi''$  are positive. What properties of the nail are responsible? [Hint: What is the nail made from? Does it behave like the open circuit or shorted inductor?] Do you think the ferrite core material is a good electrical conductor? Why or why not?
14. Launch the **High Tc** data acquisition program. This program reads the lock-in voltages  $V_x$  and  $V_y$  as well as the thermocouple voltage as measured on the Keithley 199 (set for the most sensitive scale). However, you must make sure both instruments are set up properly, and on the correct scales. The program makes these three readings at a user-defined rate. After 1024 scans are collected, new data overwrites older data. To save the data to a file that can easily be read by a spreadsheet, use the **Save Data** button on the program front panel. **Do not use the File|Save or File|Save As** menu items which are for saving the program, not the data. Besides the three voltages, the data saved includes the lock-in settings and the data collection rate. Record all other information, e.g., monitor resistance and voltage, in your log book.
15. If the thermocouple is inside the sample, slide it out. Set up the thermocouple reference ice bath. Click on the **Start** button and check the thermocouple voltage (labeled **Keithley 199** on the front panel). Take readings with the thermocouple reference/sample junctions in ice water/LN<sub>2</sub>, ice water/ice water, LN<sub>2</sub>/LN<sub>2</sub>, and LN<sub>2</sub>/ice water. You may want to recheck these calibration points at different times to assess stability/drift problems. When finished taking readings at the calibration points, insert the thermocouple junction as far as it will go into the small hole in the copper rod holding the YBCO sample.
16. Secure the YBCO sample in the probe with a single nylon screw and make sure the thermocouple is secure and will not fall out. Cool to LN<sub>2</sub> temperature as per the previous instructions while recording data. It is important to monitor the lockin and thermocouple voltages when cooling down. It takes an hour or so to cool the probe from room temperature to LN<sub>2</sub> temperature, so take data spaced about 5 seconds apart. Save the data. Graph and analyze the temperature versus time with respect to a thermal model.
17. While the sample is at LN<sub>2</sub> temperature:
  - (a) Measure the dc resistance of the primary and secondary coils and explain the results.
  - (b) Look at the secondary signal on the scope and increase the primary current until the signal becomes non-sinusoidal. How big does the applied field have to be to see this effect? At these higher fields, is the sample still superconducting? (Partially? Totally? Not at all?)
18. You should realize by now that even at LN<sub>2</sub> temperatures, the sample may not be

totally superconducting at high applied fields. With your sample at LN<sub>2</sub> temperature, and with the primary field sufficiently low (so that the sample *is* superconducting), zero the  $V_x$ -signal with the reference phase adjustment and record the setting. Be careful. If you take the applied field too low, the lock-in might be measuring noise rather than a superconducting signal. Determine how big the noise is and whether it can be a problem.

19. Set the primary current to produce a field amplitude of about 0.5 G. Raise the chamber out of the LN<sub>2</sub> (partially or totally, depending on how fast you would like the temperature to change). Take data as the sample warms up through the superconducting transition temperature. You may want to take data points more often now; the runs will be shorter. The fastest setting is 1 second per point; one second is about the minimum time this program needs to read the lock-in. (There is probably a way to do this faster if needed.)
20. While the sample is around 100 K or so: (a) Measure the dc resistance of the primary and secondary coils and explain your results. (b) Look at the secondary signal on the oscilloscope and increase the primary current as much as you did in the step 17. Interpret your results. (c) Determine and record the reference phase setting which produces no  $V_x$ -signal. Reset the reference phase to the prior value from Step 18.
21. Make several complete thermal cycles (from LN<sub>2</sub> temperature to about 100 K).
22. Repeat the measurements as you vary the amplitude of the primary magnetic field from about 0.01 G to 10 G.

**CHECKPOINT:** Data from several thermal cycles for at least one primary current setting should be recorded.

### Comprehension Questions

2. Discuss the change in the dc resistance as the coils are cooled to LN<sub>2</sub> temperature. Can resistance changes affect the phase of the monitor signal relative to the current in the primary? If so, how?
3. Compare and discuss the various reference phase settings that produce no in-phase components under the three recommended conditions. Do there appear to be temperature dependence phase shifts?
4. As the inductor was shorted, how did the  $y$  signal change? How is the direction of the change consistent with expectations.
5. Explain how your measurements demonstrate that YBCO is diamagnetic at LN<sub>2</sub> temperature?
6. Use your recordings to plot the ac susceptibility of the sample as a smooth function of temperature. What is the transition temperature and how sharp is the transition? Do you observe different thermocouple temperatures for the transition when cooling and heating through the transition? Is this real physics or an experimental problem? Discuss the issue of controlling and determining sample temperature. From your data, give your estimate of the transition temperature and its uncertainty.
7. Explain how your measurements demonstrate that  $\chi''$  for the superconductor during the transition to the superconducting

state is positive. Where is the associated energy going?

8. Discuss the reproducibility of your transition temperatures? Discuss the dependence (or lack of dependence) of the susceptibility and the transition temperature on the amplitude of the primary field. Do you see evidence of two transitions? If so, do they have the same dependence on primary field amplitude? Keeping in mind that the sample is polycrystalline, why might there be more than one superconducting transition?