

PHY 2060 Fall 2007 — Final Exam

DO NOT TURN THE PAGE UNTIL INSTRUCTED TO DO SO

Instructions: Attempt all ten questions, each of which carries a maximum of 10 points. Write your solution below each question, continuing on additional paper if necessary. Please try to write neatly!

You will receive credit only for knowledge and understanding that you demonstrate in your written solutions. It is in your best interest to write down something relevant for every question, even if you can't provide a complete answer. To maximize your score, you should briefly explain your reasoning and show all working. (This may benefit you even in the case of the multiple-choice Question 1.) Give all final algebraic answers in terms of variables defined in the problem, g (the acceleration due to gravity near the Earth's surface), G (the gravitational constant), and/or c (the speed of light). For numerical problems, take $g = 10 \text{ m/s}^2$, $G = 6.7 \times 10^{-11} \text{ Nm}^2/\text{kg}^2$, and $c = 3.0 \times 10^8 \text{ m/s}$.

1. (a)

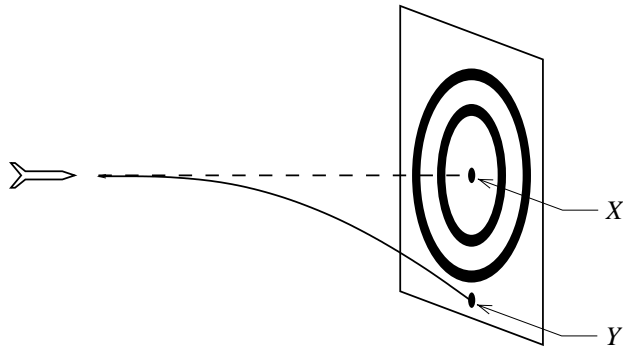

A dart is thrown horizontally toward X at 20 m/s as shown. It hits Y 0.1 s later. The distance XY is:

- i. 2 m
 - ii. 1 m
 - iii. 0.5 m
 - iv. 0.1 m
 - v. 0.05 m
- (b) A 0.20-kg particle moves along the x axis under the influence of a stationary object. The potential energy is given by $U(x) = (8.0 \text{ J/m}^2) x^2 + (2.0 \text{ J/m}^4) x^4$, where x is the coordinate of the particle. If the particle has a speed of 5.0 m/s when it is at $x = 1.0 \text{ m}$, its speed when it is at the origin is:
- i. 0
 - ii. 2.5 m/s
 - iii. 5.7 m/s
 - iv. 7.9 m/s
 - v. 11 m/s

2. With the impending energy crisis, we should start looking for unusual sources of energy. Determine the rotational kinetic energy of the Earth, and the duration over which the Earth could supply 3,327 kW of power to each of the approximately 107 million homes in the United States. Take the Earth to be a uniform sphere of mass 5.98×10^{24} kg and radius 6,370 km.
3. A sphere and a spherical shell are arranged concentrically. The sphere is made of lead (density $11,400 \text{ kg/m}^3$) and has a radius of 5.0 m. The shell, which is made of aluminum (density $2,700 \text{ kg/m}^3$), has an inner radius of 9.0 m and an outer radius of 12.0 m. The setup is located in deep space far from all astronomical objects.
- (a) Calculate the magnitude of the gravitational force on a 100-g test mass when the test mass is located 50.0 m from the common center of the sphere and the shell.
- (b) Calculate the magnitude of the gravitational force on the same test mass when it is 10.0 m from the center.
4. A pendulum is made from a piece of uniform wire, bent into the shape of an equilateral triangle having sides of length L , and freely pivoted at one corner of the triangle. Find the period of this pendulum.

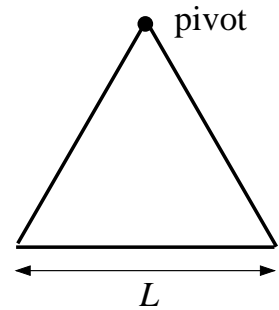

5. A small block of mass m is attached to one end of an ideal spring of natural length L and spring constant k . The other end of the spring is attached to a freely rotating axle. The mass rotates in a circle of radius r on a frictionless track inclined at an angle of θ to the horizontal, as shown in the diagram. Find the speed v that the mass must have in order for this motion to be stable.

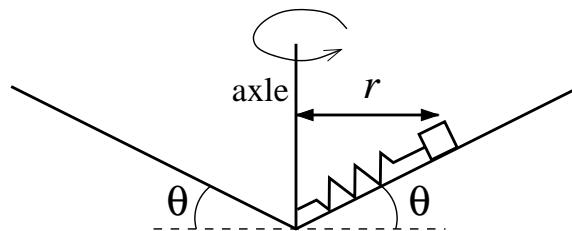

6. A uniform solid block lies flat on a solid surface (see figure). The block has mass m , width w , height h , and depth (into the page) d . The block is subject to a force of magnitude F , directed parallel to the positive x axis, and applied to the block at its top edge.

- (a) Suppose that a chock is placed behind the block (at point C in the figure) to stop it sliding. Find the minimum force F that will cause the block to tip over.

- (b) Now suppose that the chock is removed. Given that the coefficient of static friction between the block and the surface is μ_s , what is the minimum height h (for given w and d) for which it is possible to tip over the box?

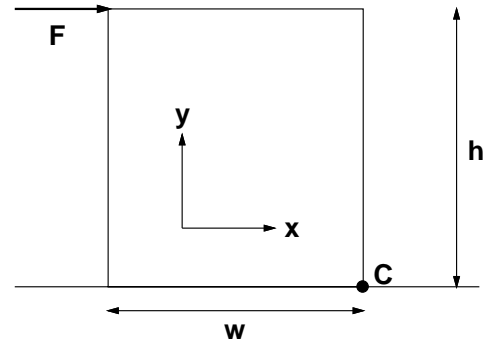

Assume that any rotation takes place around an axis that points in/out of the page.

7. A mass M is attached to one end of an ideal string. The string is wrapped several times around a uniform, cylindrical roller of mass $2M$ and radius R . A mass $3M$ is attached to the other end of the string. The cylinder is mounted so that it can turn without friction about a thin, horizontal axle passing along its cylindrical axis. The system is released from rest in the configuration shown in the figure, with the mass M hanging a distance d below the mass $3M$. How much time elapses from the moment of release until the moment when these two masses are at the same height?

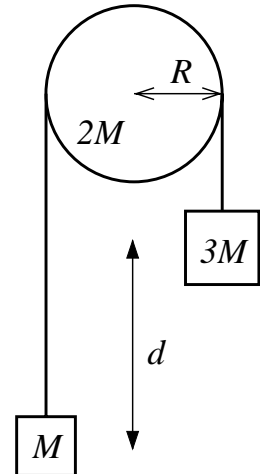

8. Two cosmic ray particles approach the Earth. As observed from the Earth, particle 1 approaches at a speed of $0.787c$ along a straight path that will take it from the North Pole to the South Pole, while particle 2 approaches at $0.612c$ along a straight path 20 degrees off from the line passing from the South Pole to the North Pole.

- (a) Find the velocity of particle 2 in the rest frame of particle 1.
 (b) Find the velocity of particle 1 in the rest frame of particle 2.

In each case, be sure to specify the directions of your axes.

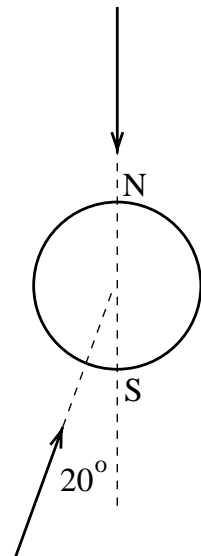

9. A wooden block of mass M rests at the bottom of a plane inclined at an angle θ to the horizontal. The coefficient of kinetic friction between the block and the plane is μ_k . A dart of mass m , traveling parallel to the inclined plane, buries itself in the block. Afterwards, the block and the dart slide a distance L along the plane before coming to a halt. Find the speed of the dart immediately before it struck the block.

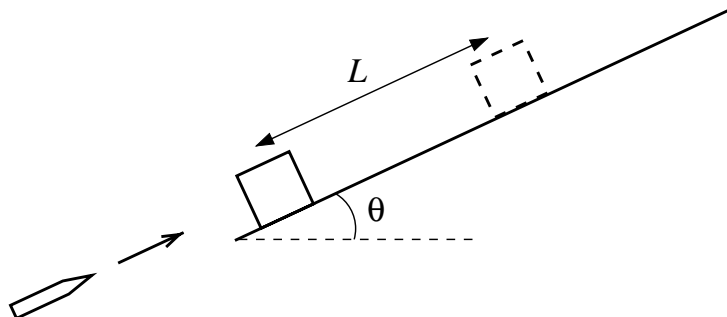

10. A point mass m is attached to two ideal springs, each of which has a spring constant k . The other ends of the springs are attached to the ground on either side of a half-cylinder of radius R in such a manner that the mass is constrained to move (without friction) around the circumference of the cylinder. The mass is displaced through a small angle θ_0 from its equilibrium position at the top of the cylinder, and then released from rest.

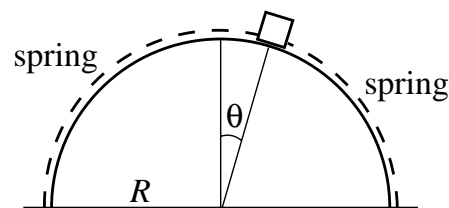

- Write down the exact equation of motion describing the time evolution of the mass' angular displacement θ .
- Under what condition will the mass oscillate about $\theta = 0$?
- Assuming that the condition in (b) is satisfied, what will be the approximate period of the oscillations about $\theta = 0$?
- Suppose that the experiment is repeated with the mass released at $\theta = 2\theta_0$. Will the period of the oscillations in this case be greater, smaller, or the same as the period when the mass was released at $\theta = \theta_0$?