

## PHY 2060 Spring 2007 — Exam 2

### DO NOT TURN THE PAGE UNTIL INSTRUCTED TO DO SO

**Instructions:** Attempt all ten questions, each of which carries a maximum of 10 points. Write your solution below each question, continuing on additional paper if necessary. Please try to write neatly!

You will receive credit only for knowledge and understanding that you demonstrate in your written solutions. It is in your best interest to write down something relevant for every question, even if you can't provide a complete answer. To maximize your score, you should briefly explain your reasoning and show all working. (This may benefit you even in the case of the multiple-choice Question 1.) Give all final algebraic answers in terms of variables defined in the problem,  $g$  (the acceleration due to gravity near the Earth's surface), and/or  $c$  (the speed of light). For numerical problems, take  $g = 10 \text{ m/s}^2$  and  $c = 3.0 \times 10^8 \text{ m/s}$ .

During this exam, you may use two formula sheets and an electronic calculator. You are not permitted (a) to consult any other books, notes, or papers, (b) to use any other electronic device, or (c) to communicate with anyone other than the proctor. In accordance with the UF Honor Code, by turning in this exam to be graded, you affirm the following pledge: *On my honor, I have neither given nor received unauthorized aid in doing this assignment.*

1. (a) A conical pendulum consists of a mass  $m$  attached to an ideal string of length  $l$ , the other end of which is anchored to a fixed point. When the pendulum is set in steady motion, the mass rotates at a constant speed  $v$  in a horizontal, circular orbit of radius  $r$ . Assume that air resistance is negligible.

Place a check to the left of any/all of the following statements that is/are necessarily true:

- i. The tension in the string has magnitude  $mv^2/r$ .
  - ii. The tension in the string is constant in time.
  - iii. The vertical forces acting on the mass sum to zero.
  - iv. The horizontal forces acting on the mass sum to zero.
  - v. A centrifugal force of magnitude  $mv^2/r$  acts on the mass to stop it hanging directly underneath the string's anchor point.
- (b) A box of mass  $m$  is on an incline that makes an angle  $\theta$  to the horizontal. The coefficient of static friction between the box and the slope is  $\mu_s > 0$ . The box remains stationary while you apply a force of magnitude  $F$  to the box as shown in the figure. This force is directed parallel to the slope.

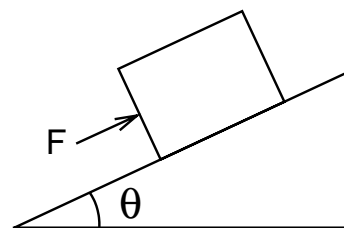

Place a check to the left of any/all of the following statements that is/are necessarily true:

- i. The applied force satisfies  $F \leq mg(\sin \theta + \mu_s \cos \theta)$ .
  - ii. The applied force satisfies  $F \leq mg(\sin \theta - \mu_s \cos \theta)$ .
  - iii. The applied force is  $F = mg(\sin \theta - \mu_s \cos \theta)$ .
  - iv. The applied force satisfies  $F \geq mg \sin \theta$ .
  - v. The applied force satisfies  $F \leq mg \sin \theta$ .
  - vi. The applied force is  $F = mg \sin \theta$ .
2. Your car gets stuck in mud. To try to free the car, you attach one end of a rope to the car and tie the rope tautly around an oak tree 30 ft away. You then pull sideways at the midpoint of the rope, as shown in the figure. Find the force exerted on the car when you pull on the rope with a 500-N force and the midpoint of the rope is displaced by 2 in from its original position. (Assume that the car does not move.)

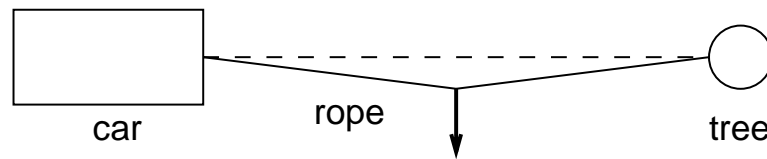

3. A plate, of uniform thickness and uniform density, is in the shape of a  $6 \times 6$  square with a  $1 \times 1$  hole and a  $2 \times 1$  protrusion, as shown in the figure. Find the center of mass position relative to the bottom left corner of the plate.

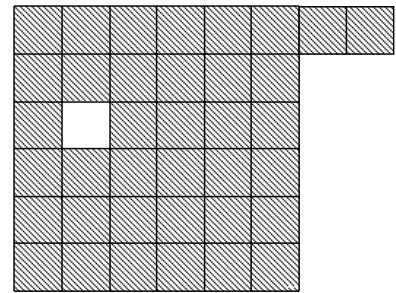

4. A point mass  $m$  is attached to two ideal strings, each of length  $L$ . The strings are attached to a vertical rod, and the rod is rotated in such a manner that the mass undergoes uniform circular motion at speed  $v$  in a horizontal plane, and the strings make equal angles  $\theta$  to the horizontal (as shown in side view at right).

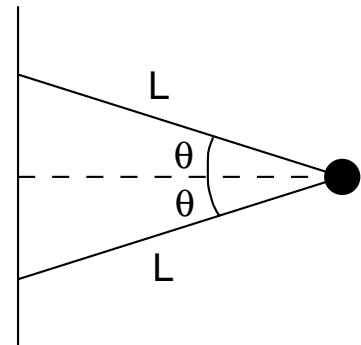

- (a) Find the tension in each of the strings.
  - (b) What is the minimum value of  $v$  for which the configuration shown is stable?
5. A two-dimensional object is formed by the region of the  $xy$  plane enclosed by the curves  $y = \sqrt{x} - x$  and  $y = x - \sqrt{x}$ . Find the coordinates of the object's center of mass.
6. A hockey puck of mass 0.15 kg moving at 3.0 m/s along the  $+x$  axis slides into a second, identical puck that is initially stationary. After the collision, the first puck is traveling at speed  $v_1$  at angle  $+25^\circ$  measured (counter-clockwise) from the  $+x$  axis; the second puck is traveling at speed  $v_2$  at angle  $-55^\circ$  measured from the  $+x$  axis. Find  $v_1$  and  $v_2$ .

7. Three carts are spaced out as shown in the figure along a straight track that permits the carts to move (without friction) in only one dimension. Carts 1 and 2 have mass  $m$ , and cart 3 has mass  $4m$ . Carts 2 and 3 are initially stationary, while cart 1 is initially moving towards cart 2 at speed  $v$ . Assume that all subsequent collisions are elastic. Find the final velocity of each cart after all collisions are over.

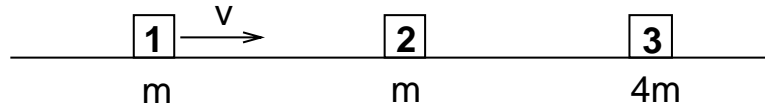

8. Consider a crude elevator formed from a cage of mass  $M$  hanging from an ideal string that passes over a pair of ideal pulleys and is attached at the other end to a counterweight, which also has mass  $M$ . When a load  $m$  is placed in the cage, it begins to accelerate downward. For safety reasons, it is necessary to limit the speed with which the elevator descends. This goal can be accomplished by pressing the side of the cage against a vertical wall with a horizontal force  $F$ . The coefficient of kinetic friction between the cage and the wall is  $\mu_k$ .

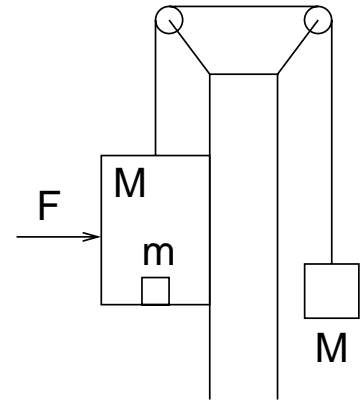

- (a) Assume initially that  $F = 0$ . What is the magnitude of the elevator's acceleration and what is the tension in the string?
- (b) Now let  $F$  be nonzero. What value must it take to keep the elevator descending at a constant velocity?
9. A block of mass  $m$  is in contact with a plane inclined at angle  $\theta$  to the horizontal. The coefficient of static friction between the block and the slope  $\mu_s$  is too small for the block to remain in equilibrium on the slope by itself. In order to maintain equilibrium, an ideal string is attached to the block in two places, as shown in the figure. The string is tensioned by passing it over two ideal pulleys, which are positioned so that the string runs parallel to the slope at one point of attachment to the block and perpendicular to the slope at the other attachment point.

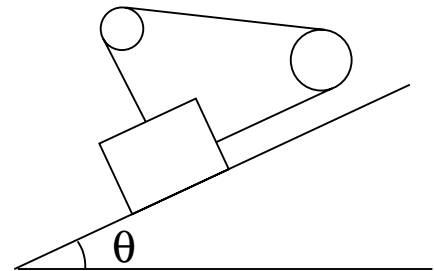

- (a) Find the greatest and smallest values of the tension in the string for which the system can remain in static equilibrium, assuming that  $\mu_s < 1$ .
- (b) Repeat part (a), assuming instead that  $\mu_s > 1$ .

10. A 70-kg stuntman takes off straight upwards from the ground wearing a jet pack that burns 2.0 kg of fuel per second and ejects the burned fuel vertically downward at an exhaust speed of 750 m/s (relative to the pack). The initial mass of fuel is 50 kg, while the non-fuel parts of the jet pack have a mass of 20 kg. Find the stuntman's velocity at the moment the fuel runs out. Neglect air resistance and any change of the gravitational constant  $g$  with altitude.

Hint: Start from the rocket equation

$$M \frac{d\mathbf{v}}{dt} = \mathbf{F}_{\text{ext}} + \mathbf{v}_{\text{rel}} \frac{dM}{dt}.$$

The external force has magnitude  $Mg$ , where  $M$  is the combined mass of the stuntman, the jet pack, and the remaining fuel. You should be able to integrate this differential equation almost as easily as in the case  $\mathbf{F}_{\text{ext}} = \mathbf{0}$  treated in class.